

LASER PROBING OF OPTICAL MEDIA WITH NANODIMENSIONAL PARTICLES

V. K. Goncharov, K. V. Kozadaev,
M. I. Kunitskii, and M. V. Puzyrev

UDC 621.373.826.004.14:53.082.5

The diameters and concentrations of copper nanoparticles on quartz glass have been measured with the laser-probing method. To confirm the results obtained, analysis of the nanodimensional particles by means of atomic-force microscopy has been performed.

Introduction. In making optical glasses by using sol-gel technology, one has to control the sizes and concentrations of nanoparticles in an optically transparent medium. In modern scientific practice, several methods for carrying out this control are known: electron microscopy, small-angle neutron scattering, and atomic-force microscopy. However, the above methods have many limitations. For instance, electron microscopy presupposes labor-consuming preparation of the test specimen and the use of sophisticated expensive equipment. The facility for the method of small-angle neutron scattering incorporates a neutron-beam source, which is often a nuclear reactor. The basis of atomic-force microscopy is a sophisticated and expensive atom probe incorporating modern ultrahigh-vacuum systems and highly complex computer aggregates. A limitation of the atomic-force method is that it is impossible to obtain information about the internal structure of the specimen. Moreover, the above methods are time-consuming and, as a rule, presuppose destruction of the material being investigated.

In the present paper, we propose to use the method of laser probing to control the sizes and concentrations of nanoparticles in a transparent medium.

Method of Laser Probing. To investigate the parameters of the liquid-drop phase of the erosion laser torch of metal targets, a laser-probing method was developed in [1–3]. Its main point, as applied to the aim of the present work, is as follows. The probing laser radiation is incident on the glass specimen and is absorbed and scattered by particles. For the case of the Rayleigh approximation, where $\lambda \gg d$, the relation [1, 4]

$$\frac{Q_{\text{scat}}}{Q_{\text{abs}}} = \frac{\pi^3}{9} \left(\frac{d}{\lambda} \right)^3 \frac{(n^2 - \chi^2 - 1)^2 + 4n^2\chi^2}{n\chi} \quad (1)$$

holds. Here $n = n_{\text{part}}/n_{\text{med}}$ and $\chi = \chi_{\text{part}}/\chi_{\text{med}}$.

Under the condition of single scattering (the photon scattering mean free path should be larger than the size of the object being probed), the equality $P_{\text{scat}}/P_{\text{abs}} = Q_{\text{scat}}/Q_{\text{abs}}$ holds. In the experiment, P_{inc} , P_{trans} , and P_{scat} are measured. From the balance $P_{\text{inc}} = P_{\text{trans}} + P_{\text{scat}} + P_{\text{abs}}$ one can determine P_{abs} . Thus, determining experimentally the ratio $P_{\text{scat}}/P_{\text{abs}}$, one can find the averaged diameter of particles by formula (1).

The formula for calculating the concentration of particles can be obtained in the following way. The extinction efficiency $Q_{\text{ext}} = S_{\text{loss}}^1/(\pi r^2)$ [4]. The number of particles in the volume of the specimen being probed $N_v = NSl$. Then the radiation-loss section on all particles of the volume being probed $S_{\text{loss}} = S_{\text{loss}}^1 N_v = Q_{\text{ext}} \pi r^2 NSl$. Under the condition of single scattering, the ratio of the radiation-loss section on the probed volume particles to the probing-beam cross section is equal to the relative loss factor $K_{\text{loss}} = (P_{\text{scat}} + P_{\text{abs}})/P_{\text{inc}}$, i.e., $S_{\text{loss}}/S = K_{\text{loss}} = Q_{\text{ext}} \pi r^2 Nl$, whence we can determine the concentration

A. N. Sevchenko Scientific-Research Institute for Applied Physical Problems, Belarusian State University, 7 Kurchatov Str., Minsk, 220064. Translated from *Inzhenerno-Fizicheskii Zhurnal*, Vol. 78, No. 6, pp. 122–125, November–December, 2005. Original article submitted February 25, 2004.

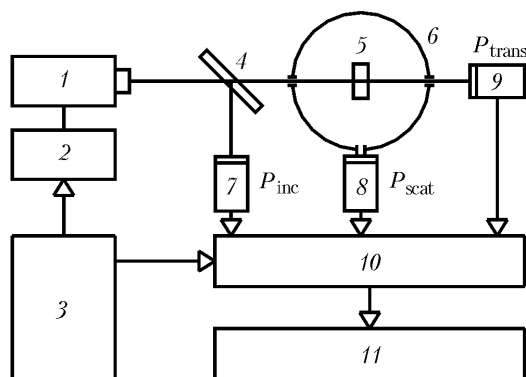

Fig. 1. Experimental facility for investigating the sizes and concentrations of nanoparticles in an optically transparent medium: 1) ruby laser; 2) ruby laser power unit; 3) timing system; 4) dividing plate; 5) investigated specimen; 6) integrating sphere; 7–9) sensor recording power of the probing radiation incident on the specimen (7), scattered by it (8), and transmitted through it (9); 10) ADC; 11) computer.

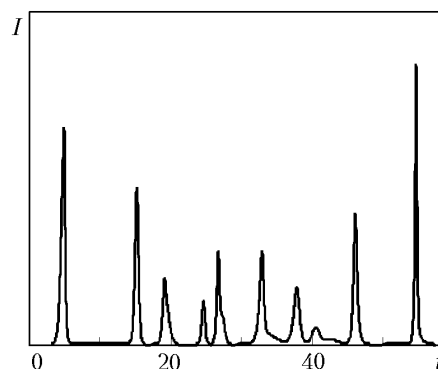

Fig. 2. Time sample of the ruby laser probing radiation pulse.

$$N = \frac{K_{\text{loss}}}{\pi r^2 Q_{\text{ext}} l} \quad (2)$$

Thus, determining K_{loss} experimentally and computing Q_{ext} theoretically (the method for computing Q_{ext} , according to Mie theory, is described in detail in [4]), one can find the averaged concentration of particles in an optically transparent medium by formula (2).

Experimental. Experimental studies were made on quartz glass specimens containing copper nanoparticles in the bulk.

The sizes and concentrations of copper particles were controlled by the experimental facility schematically represented in Fig. 1. The investigated specimen 5 is placed in the center of the integrating sphere 6. The probing radiation from the ruby laser 1 is incident, through a hole in the sphere, on the specimen. The time sample of duration 60 μsec of a millisecond ruby laser radiation pulse in the regime of free generation is shown in Fig. 2. Part of the laser radiation is directed by means of the dividing plate 4 to the optical sensor recording the radiation power incident on the specimen 7. Through a second hole in the sphere the radiation transmitted through the specimen is output, and its power is controlled by the optical sensor 9.

Part of the radiation scattered by the specimen and uniformly distributed over the inner diffusing surface of the sphere strikes the optical sensor 8 through the third hole in it.

Analog signals from the sensors 7, 9, and 8 are sent to the analog-to-digital converter (ADC) 10 and then are processed by the computer 11. For timing the operation of the laser and the ADC the timing system 3 is used. In experiments, a four-channel ADC with a sampling time of 25 nsec and a 10-bit capacity is used. The ADC allows storage of up to 64,000 data values per channel, which corresponds to a time interval of 1.6 msec. A special program based on formulas of Mie theory [4] that are more exact than expression (1) computes the averaged diameters and concentrations of nanoparticles. The use of the formulas of Mie theory widens the validity range of the method, since, unlike formula (1), they hold for a wider range of particle sizes.

It has been established [5] that single scattering is observed when the probing-laser-radiation loss under interaction with particles (scattering and absorption) does not exceed 30%. The specimen thickness was chosen in accordance with this.

The values of the complex refractive index of copper and quartz were taken from [6, 7] for a wavelength close to the ruby laser radiation wavelength $\lambda = 694.3 \text{ nm}$ used as a probing radiation.

TABLE 1. Sizes and Concentrations of Copper Particles in Quartz Measured by the Method of Laser Probing

Complex refractive index of copper		Refractive index of the medium $n_{\text{med}} = n_{\text{SiO}_2}$	Averaged diameter of particles d , nm	Averaged concentration of particles $N \cdot 10^{12}$, cm^{-3}	Literature source of values n_{part} and χ_{part}
n_{part}	χ_{part}				
0.11	3.74	1.4585	35	8.7	[6]
0.399	3.97	1.4585	51	0.93	[7]

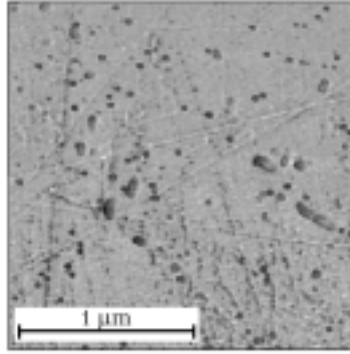

Fig. 3. Image of the surface relief of quartz glass with copper particles upon etching in hydrofluoric acid obtained by means of an atomic-force microscope. The scale is the same along both axes.

Analysis of the Results Obtained. The values of the diameters and concentrations of copper particles in the quartz glass obtained by the proposed method for n_{part} and χ_{part} from different sources are given in Table 1.

It should be noted that for our case ($d \approx 50$ nm, $nd/\lambda \approx 0.23$) the particle diameters calculated by the approximate formula (1) and by the formulas of Mie theory differ insignificantly. In controlling larger particles, to increase the measurement accuracy, one has to use the formulas of Mie theory.

To confirm the results obtained by the method of laser probing, analysis of the specimen surface by means of atomic-force microscopy has been performed. To form a surface relief, the investigated glass was placed in hydrofluoric acid, which etched off quartz, leaving copper. The image of the surface relief of the quartz glass with copper particles obtained by the atomic-force microscope is shown in Fig. 3.

The mean value of the particle diameter established from Fig. 3 is ~ 50 nm at a mean square spread of $\pm 40\%$.

The values of the particle diameters measured by the method of laser probing are in agreement with the values obtained by means of atomic-force microscopy. However, to increase the exactness of the method, experimental determination of the complex refractive index of the copper used to prepare particular specimens is needed.

Conclusions. The method of laser probing permits fairly accurate real-time determination of the averaged sizes and concentrations of particles in a transparent medium. It should be noted that the method is applicable for controlling changes in the sizes and concentrations of particles in fast processes. An additional advantage of the proposed method is the possibility of controlling parameters directly during the process of material preparation.

NOTATION

d , particle diameter, nm; I , radiation intensity, rel. unit; K_{loss} , relative loss factor; l , length of interaction between the probing radiation and the specimen being investigated, cm; N , numerical concentration of particles, cm^{-3} ; N_v , number of particles in the investigated volume, cm^{-3} ; n_{med} , refractive index of the medium; n_{part} and χ_{part} , real and imaginary part of the complex refractive index of the particle material; Q_{scat} and Q_{abs} , scattering and absorption efficiencies (ratio of the scattering and absorption section to the cross-section area of the particle); Q_{ext} , extinction efficiency (ratio of the total scattering and absorption loss of the radiation to the cross-section area of the particle); P_{inc} ,

P_{trans} , P_{scat} , and P_{abs} , powers of the probing radiation incident on the specimen, transmitted through the specimen, scattered and absorbed by it, respectively, rel. unit; r , particle radius, cm; S_{loss}^1 , radiation-loss section on one particle, cm^2 ; S_{loss} , radiation-loss section on all particles, cm^2 ; S , cross section of the probing laser beam, cm^2 ; t , time, μsec ; λ , probing-radiation wavelength, nm. Subscripts: 1, one particle; inc, incident; abs, absorbing; loss, loss; trans, transmitted; scat, scattered; med, medium; part, particle; ext, extinction; v, volume.

REFERENCES

1. V. K. Goncharov, V. I. Karaban', and V. A. Ostrometskii, Screening of laser radiation by products of destruction of different metals, *Kvantovaya Elektron.*, **13**, No. 6, 1235–1240 (1986).
2. V. K. Goncharov, V. I. Karaban', A. V. Kolesnik, and I. M. Radyuk, Space-time distribution of liquid droplets in an erosion torch under the effect of laser radiation on a lead target, *Kvantovaya Elektron.*, **15**, No. 12, 2575–2577 (1988).
3. V. K. Goncharov, V. L. Kontsevoi, M. V. Puzyrev, and A. S. Smetannikov, Real-time control of the size of particles of the fine-dispersed condensed phase of erosion plasma flows. *Prib. Tekh. Eksp.*, No. 5, 146–155 (1995).
4. C. F. Bohren and D. R. Huffman, *Absorption and Scattering of Light by Small Particles* [Russian translation], Mir, Moscow (1986).
5. H. C. van de Hulst, *Light Scattering by Small Particles* [Russian translation], IL, Moscow (1961), p. 87.
6. Landolt-Bornstein, *Zahlenwerte und Funktionen aus Physik, Chemie, Astronomie, Geophysik und Technik*, 2 band, 8 teil (1962).
7. M. A. Ordal, J. Bell Robert, R. W. Alexander, L. L. Long, and M. R. Querry, Optical properties of fourteen metals in the infrared and far infrared: Al, Co, Cu, Au, Fe, Pb, Mo, Ni, Pd, Pt, Ag, Ti, V, and W, *Appl. Opt.*, **24**, No. 24, 4493–4499 (1985).